

## Start Line Control

What does SLC (Start Line Control) do for a racer? The SLC will guarantee the same start line rpm every time. The racer never looks away from the tree, the racer does not get distracted and this helps in cutting better lights and it drastically reduces converter temperature insuring not only that the parts will last longer but the car will be more consistent as the converter temperature will be the same every time.

This is a must have for every DYO racer. The SLC can be configured and used different ways.



### Method 1 is with a delay box.

Slowly idle into "stage", once the front wheel breaks the start line beam and lights the stage light you press the transbrake button to set the transbrake and the SLC. The throttle pedal goes to the floor telling the driver that the system is armed, but the engine continues to idle because the butterflies are still closed. Once you release the transbrake button it takes the engine to wide open throttle and then the start line rpm is regulated by the converter or the two step chip in the ignition controller, depending upon how you have your car configured. This insures that the engine stays revved to the same rpm every time for the same amount of time.



### Method 2 is with out a delay box.

Slowly idle into "stage", once the front wheel breaks the start line beam and lights the stage light you press the transbrake button to set the transbrake and the SLC. The throttle pedal goes as far as you have it adjusted for. This is usually 80%-90% of the full travel to the throttle stop under the throttle pedal. This is adjusted before you get to the starting line. The engine continues to idle and will idle until the driver pushes the throttle all the way to the stop. This is done only after both drivers are fully staged. Once the driver pushes the pedal to the stop the engine revs up the amount that you have it adjusted for with the throttle linkage. Now when the driver releases the transbrake button it releases the transbrake and activates the SLC opening the throttle to wide open. The driver never has to look away from the tree to get the stage rpm right. The engine spends the least amount of time at the stage rpm which limits the converter heat.

We built our first SLC in response to a discovery. We had a temperature gauge in the oil pan of our transmission to monitor the trans temperature but every time we wanted to remove the transmission you had to drain the pan and remove the temperature gauge probe. We made a block to put the temperature probe into and used the oil coming from the converter (bottom port on the Powerglide) to measure the temperature. We were shocked to see how fast the heat rose at stage rpm. We saw almost 100F per second of heat rise. There is no way this could be good for the converter or the consistency of the car. By limiting the time spent at stage rpm it not only made the car more consistent but the driver better as well as now they never have to look away from the tree and they have confidence that the start line rpm will always be right.

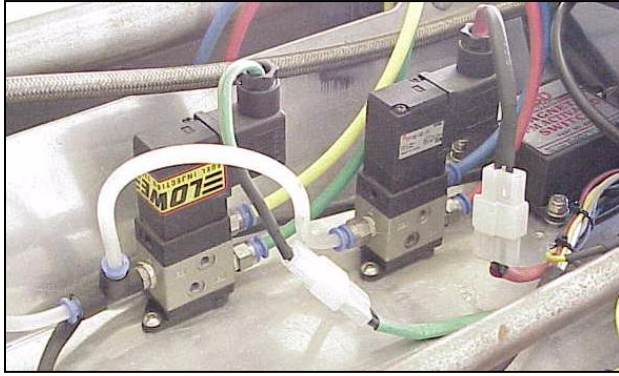

**You can win races without one of these, but you will win *more* races with a **LOWE** Start Line Control unit.**

**Complete kit** (less CO2 bottle and regulator – available separately)

List Price \$ 649.00+

Racer Decal Discount Price – \$599.00+

Cylinder (10-32 thread on body)

Cylinder travel stop – adjustable

Heavy duty quick release cable end with 10-32 thread to suit most injector arms.

Solenoid Valve – dual acting

Hose and Fitting Kit

4 ea - Straight hose ends (quick disconnect)

4 ea - 90 degree hose ends (quick disconnect)

4 meters of 6mm Polyethylene tube Green

4 meters of 6mm Polyethylene tube Black

4 meters of 6mm Polyethylene tube White

All prices are plus gst and shipping if applicable You will need a source of CO2 to operate this system. Either a 2 pound or a 5 pound bottle system will work and the regulator needs to be set at 150 psi. Compressed air could be used but it would have to be recharged before each run.

## Accessories



Bell crank 90 degree – Allows the linkage to change direction. In some applications this makes a much tidier package. 1.75" arms with ¼" id bearing. Part Number 53065-89331 List 115.00+ Racer Decal Discount \$ 95.00+

Speed controller - If you control the speed of the co2 exhaust from the cylinder as it moves it allows you to slow the opening of the cylinder allowing the car to launch better on a slick starting line Fully adjustable speed controller \$ 38.00+

All we need to ship your order is your credit card details and a shipping address. We accept Master Card and Visa. There is a printed number on the back of your credit card on the signature line. Would you give us the last three digits of that number. Please include your phone number as well. Prices are in AUD (Australian Dollars) + GST





Racer Decal

## CO2 Bottle and Accessories

This CO2 bottle is 2 inches in diameter and is used to power control devices on your race car. It can be used for shifting gears, Start Line Control, Trans Brakes, parachute release and fuel management systems. The only limits of use are your imagination. Part Number 84105-01011

List Price \$250.00+



Racer Decal Discount \$210.00+

Regulator for CO2 bottle to step the pressure down from over 1200 psi to a preset pressure of 145 psi (10 bar), comes with nipple and nut to connect to CO2 bottle. Part number 53702-00018

List Price \$ 195.00+

Racer Decal Discount \$ 175.00+



Bottle bracket to mount the 2" CO2 bottle in your car. Flat back mount allows mounting to any flat surface with two 1/4" unc bolts provided. One screw opens the bracket allowing the bottle to slide into place quickly and easily. Part number 84090-82000

List Price \$ 89.00

Discount \$ 70.00+



All we need to ship your order is your credit card details and a shipping address. We accept MasterCard and Visa. There is a printed number on the back of your credit card on the signature line.

Would you give us the last three digits of that number. Please include your phone number as well. Prices are in AUD (Australian Dollars) + GST (if applicable) GST does not apply to orders from outside Australia. Price does not include shipping. All prices are subject to change without notice. Prices must be verified at time of purchase only.



Billet aluminium - 4.375 Bottle mount bracket  
Steel chassis mount for billet aluminium 4.375 bottle mount

## Installation Notes:

The LOWE SLC (Start Line Control) can be installed in a push or pull cable application. In either case you must insure that the throttle pedal has a travel stop as you do not want the rotation stop on the injector or carburetor being the travel stop for the system as you will inflict damage to the injector, carburetor or the linkage if you do not have a pedal travel stop. Since all small diameter controls have many times the strength if you place them in tension versus compression it is highly recommended that your throttle linkage is engineered to put the cable and all the hardware in a tension environment. This means you should have a pull throttle cable and as noted above it should have a pedal stop so the only load the cable, levers or cylinders see are the loads imposed by the throttle return spring. Not all race cars have the same amount of cable travel to achieve the transition from idle to wide open throttle. Since they can all be different the LOWE SLC launch cylinder has a travel stop provided to assist you in calibrating your system to suit your application. Set the travel stop to the amount of travel needed.

The LOWE SLC launch cylinder has a 10-32 thread provided for those who want to just thread the throttle cable into the bottom of the cylinder as it works well in many situations this way. This is pictured in the photo above. Some clients prefer to put the launch cylinder out by the injector others prefer to put it down by the throttle pedal. Each situation must be engineered to suit your application. Some clients will make a bracket and run the cable parallel to the cylinder. This will shorten the overall length and it can create a side load situation on the cable.

## Installation Instructions

for locating the throttle cable mounting bracket and setting the LOWE SLC cylinder travel stop.

The location of the throttle cable mounting bracket on the cylinder end will vary depending upon if you are using this with a delay box or not. See Method 1 and Method 2 above.

Method 1 (with delay box) keeps the throttle fully closed once the system is activated. Set this by installing the LOWE SLC launch cylinder in the cable and connecting to the foot throttle pedal or injector throttle arm. With the throttle butterflies fully closed and the LOWE SLC launch cylinder fully extended and the throttle foot pedal against the stop under it now locate the cable mounting bracket and attach it. Once this is done, when activated the SLC launch cylinder will extend and push the foot throttle pedal to the "floor" all the way to the stop while leaving the throttle butterflies fully closed and the engine will continue to idle. Now you have to set the LOWE SLC launch cylinder travel stop. Remove the throttle return springs and while holding the throttle foot pedal against the stop open the throttle wide open and move the LOWE SLC launch cylinder stop against the end of the cylinder and lock in place. Test with low pressure shop air before connecting to the CO2 cylinder regulator preset to 145 psi. Reinstall throttle return springs.

The stroke of the launch cylinder has a travel stop to allow you to adjust it to the range of motion that your throttle cable actually moves.

Method 2 (without delay box) keeps the throttle NEARLY fully closed once the system is activated. To install insure the foot throttle pedal stop has several turns of adjustment available to allow the pedal stop to be adjusted to allow slightly more opening. Now, after installing the LOWE SLC launch cylinder in the cable and connecting to the foot throttle pedal or injector throttle arm. With the throttle butterflies fully closed and the LOWE SLC launch cylinder fully extended and the throttle foot pedal against the stop under it now locate the cable mounting bracket and attach it. Once this is done, when activated the LOWE SLC launch cylinder will extend and push the foot throttle pedal to the "floor" all the way to the stop while leaving the throttle butterflies fully closed and the engine will continue to idle (with the current throttle stop position). Now you have to set the LOWE SLC launch cylinder travel stop against the end of the cylinder.. Remove the throttle return springs and while holding the throttle foot pedal against the stop open the throttle wide open and move the LOWE SLC launch cylinder stop against the end of the cylinder and lock in place. Test with low

pressure shop air before connecting to the CO2 cylinder regulator preset to 145 psi. Reinstall throttle return springs.

With the adjustments as described above this will launch the car at an idle position. Some racers like to "leave" at "just off idle", "smooth", or even more rpm. The LOWE SLC allows this adjustment. By adjusting the throttle foot pedal travel stop to slightly open the throttle butterflies at wide open throttle with the LOWE SLC activated you can preset the launch rpm right in the pits before you even go to the starting line. Once you do this you must reset the LOWE SLC launch cylinder travel stop to accommodate this new length.

How the driver would use this is to stage their car, either first or last it does not matter, and activate the LOWE SLC. In doing so the throttle pedal goes to the "floor" but not to the pedal stop and continues to idle. In doing so it does not build un-necessary heat in the engine or converter. ONLY once the driver sees that both the stage and prestage bulbs are lit for BOTH lanes only then does the driver push the pedal all the way to the travel stop increasing the engine RPM to the preset level. Knowing their spot on the tree all the driver does is release the transbrake button at the right time and the car opens the throttle and releases the transbrake insuring the most accurate and consistent launch program.

To give or check the final adjustments before connecting to the CO2 bottle and regulator preset to 145 psi use shop air and a regulator set at only 15-20 psi to cycle the system to insure it operates correctly and all adjustments are correct. Reinstall throttle return springs.

## **Step by step cylinder mounting process**

1. Make sure the race car has an adjustable and robust throttle pedal stop.
2. Set the throttle pedal stop to a comfortable position for the driver when the pedal is at wide open throttle.
3. From this position make sure the throttle pedal stop has adjustment in both directions.
4. Mount the SLC cylinder body to the push - pull throttle cable.
5. Make sure the SLC cylinder shaft stop is installed on the SLC cylinder shaft but leave the stop loose. Do not connect CO2 hoses yet.
6. Mount the SLC cylinder shaft ball joint to the throttle shaft arm.
7. Extend the SLC cylinder to the maximum length and hold the throttle pedal down against the throttle pedal travel stop.
8. In this position mark and mount the throttle cable housing quick release bracket to a secure and robust bracket.
9. Hold the throttle pedal against the throttle pedal stop and use your hand to open the throttle butterflies to wide open position – now slide the SLC launch cylinder travel stop against the top of the launch cylinder and secure in place with the lock screws.
10. This sets the launch RPM at idle position. If you want to increase the launch RPM adjust the throttle pedal travel stop to slightly open the throttle butterfly plates when the SLC is activated and the throttle pedal is depressed to the throttle pedal travel stop.

11. After a few starts and adjustments you will have the start line RPM preset so as a driver you never have to look away from the tree and get caught out looking at the tach when the tree goes green.

## Wiring diagram

The wiring diagram included is a suggested method of wiring the SLC. This is not the only method but one that we use on our race cars. We use a heavy relay to operate the transbrake solenoid as the transbrake solenoid uses more power than the transbrake control switch can reliably handle. We do use a relay for the shift solenoid but not the SLC control solenoid as the SLC solenoid gets its power from the transbrake relay switch and not the transbrake switch directly. Some racers use fuses in the electrical system but others don't as they fear vibration causing a fuse failure and the subsequent loss of a race because the fuse blew.

If you are using a delay box the SLC wires directly into the delay box and will activate with the box controlling it. It is recommended to use a relay in this situation as the delay box circuit is not robust enough to provide enough current flow to activate the SLC CO2 solenoid.

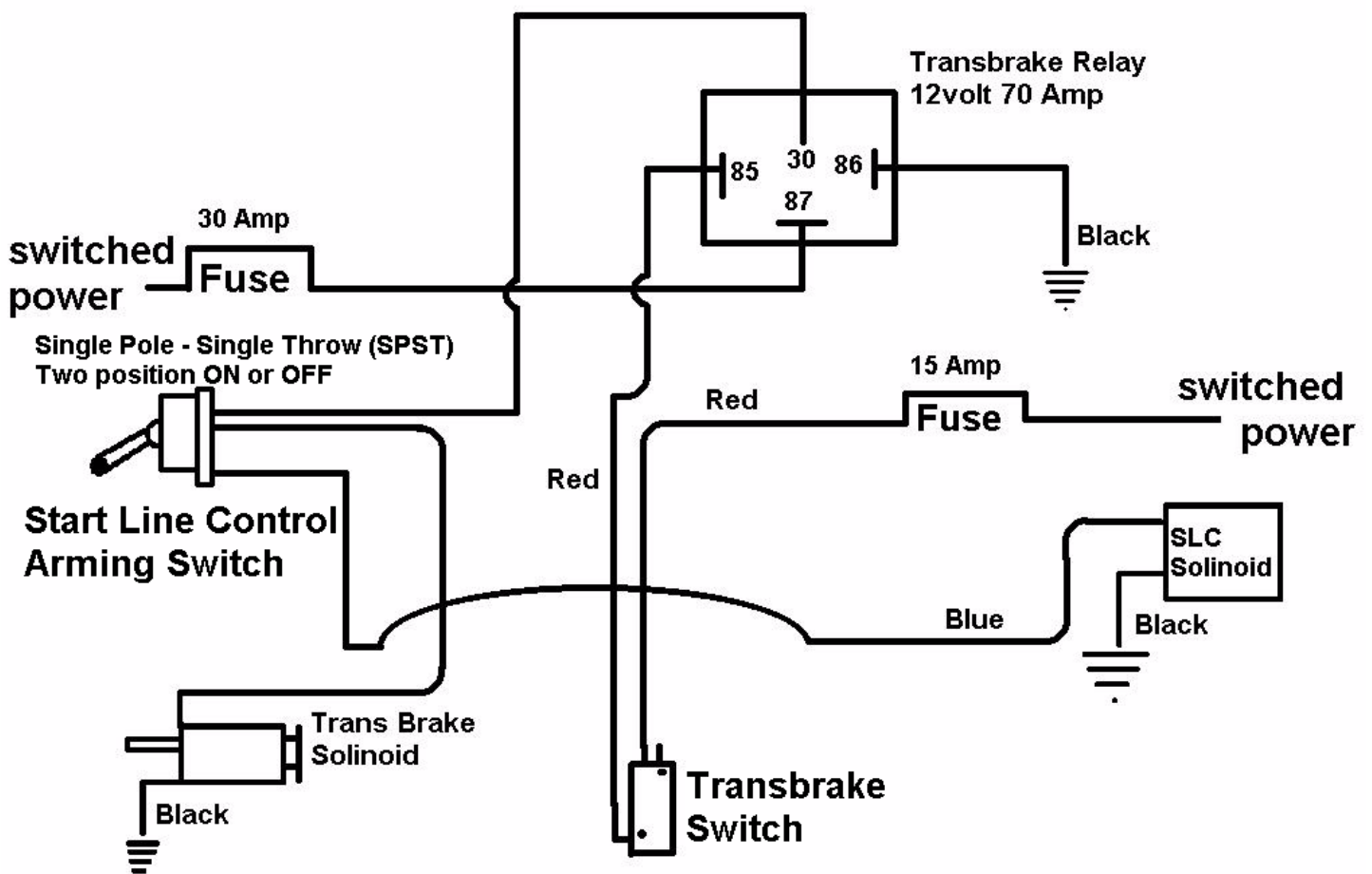

# Plumbing the air lines

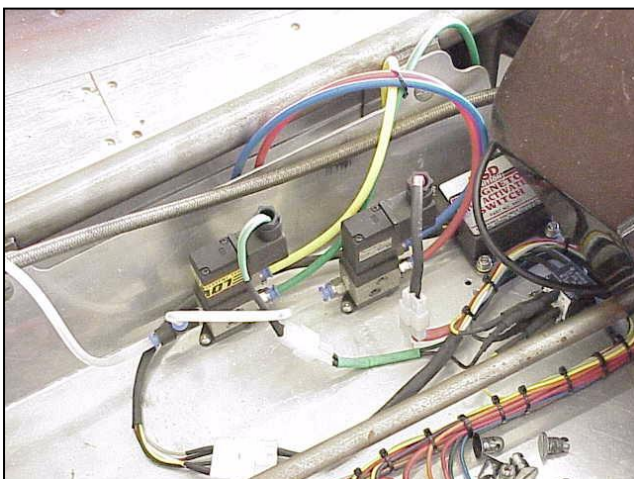
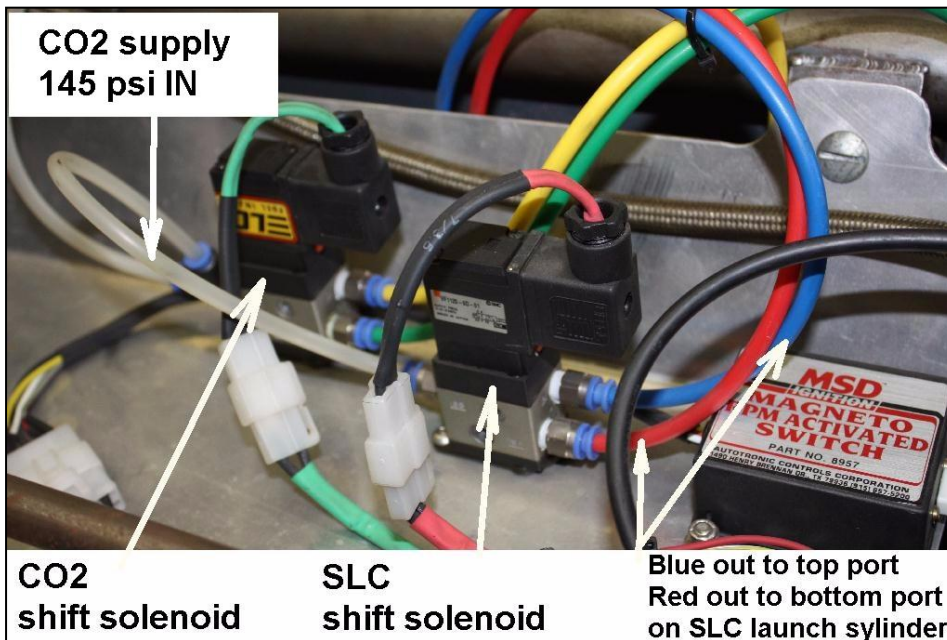
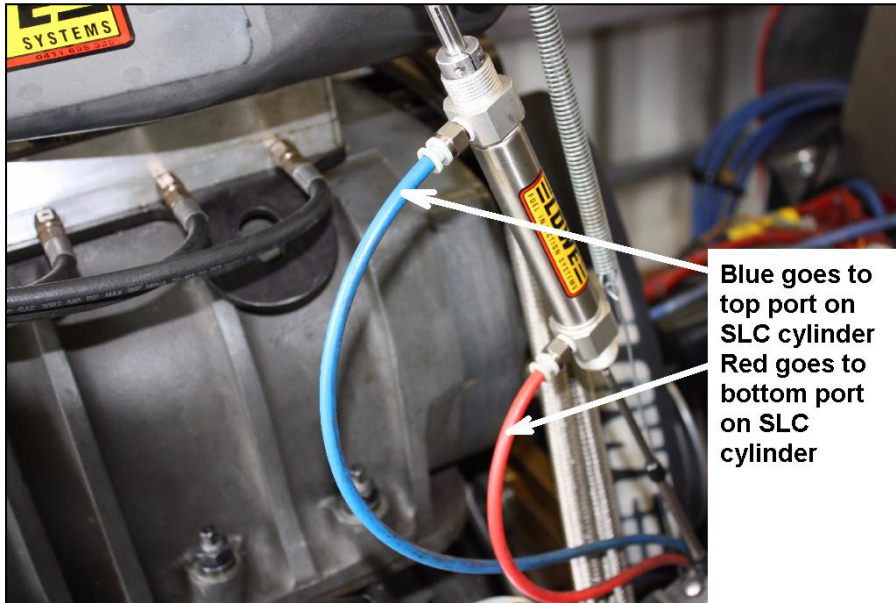

In these photos you can see the Red and Blue hoses for the SLC controls. The **Blue** hose connects to the top port on the double acting solenoid and the top port of the SLC launch cylinder. The **Red** hose connects to the bottom port of both of the double acting solenoid and the SLC launch cylinder. The white hose is the supply side of the solenoid. You may also notice the Yellow and Green hoses of the CO2 shifter solenoid which is activated by the MSD Magneto RPM activated switch you see in the upper left of the photo.

**Step 1 - Start Line Control NOT activated, throttle operates as normal. This is burn out and reverse position.**

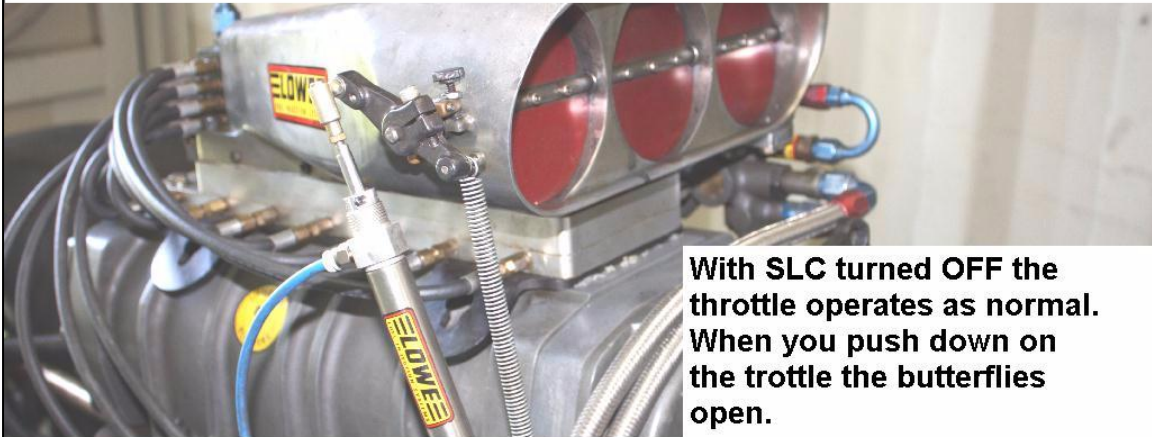

**With SLC turned OFF the throttle operates as normal. When you push down on the throttle the butterflies open.**

After installing the LOWE SLC launch cylinder in the cable and connecting to the foot throttle pedal or injector throttle arm. With the throttle butterflies fully closed and the LOWE SLC launch cylinder fully extended and the throttle foot pedal against the stop under it now locate the cable mounting bracket and attach it. Once this is done, when activated the LOWE SLC launch cylinder will extend and push the foot throttle pedal to the "floor" all the way to the stop while leaving the throttle butterflies fully closed and the engine will continue to idle (with the current throttle stop position). Now you have to set the LOWE SLC launch cylinder travel stop against the end of the cylinder.

**Step 2 - Start Line Control activated, transbrake ON but throttle not pushed to the stop - yet. Engine still idles**

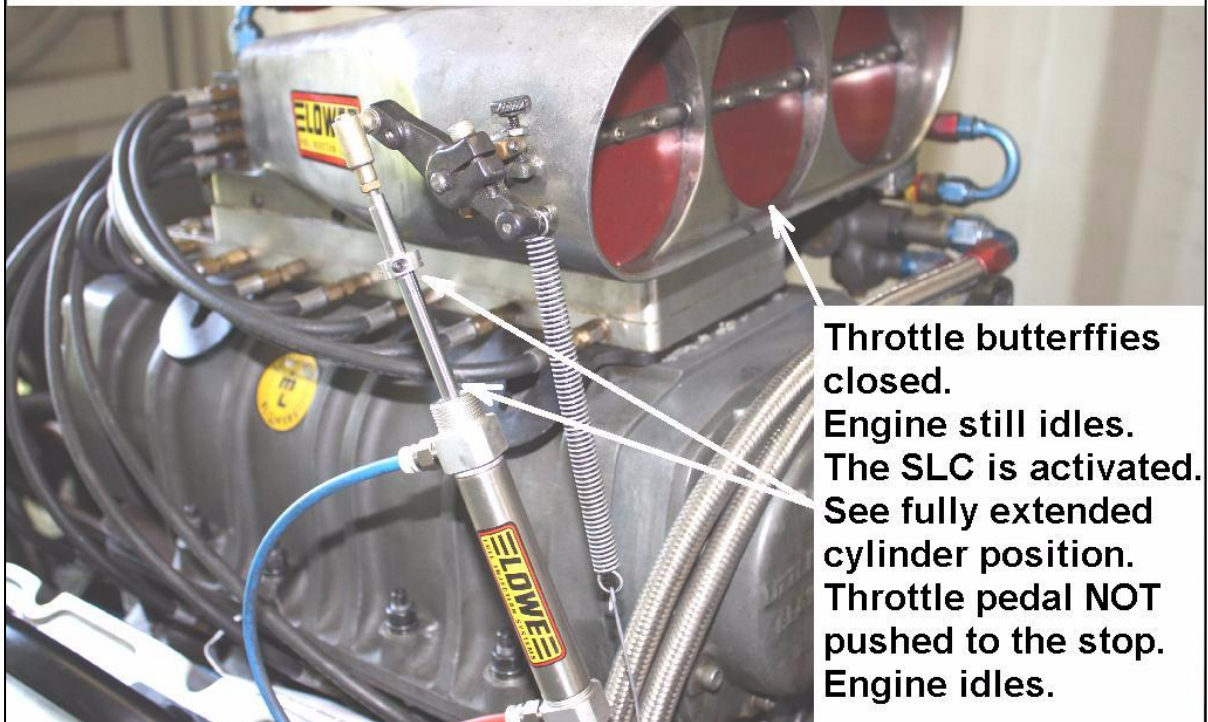

**Throttle butterflies closed.  
Engine still idles.  
The SLC is activated.  
See fully extended cylinder position.  
Throttle pedal NOT pushed to the stop.  
Engine idles.**

**Step 3 - Start Line Control activated, trans brake ON and throttle pedal pushed to the stop.**

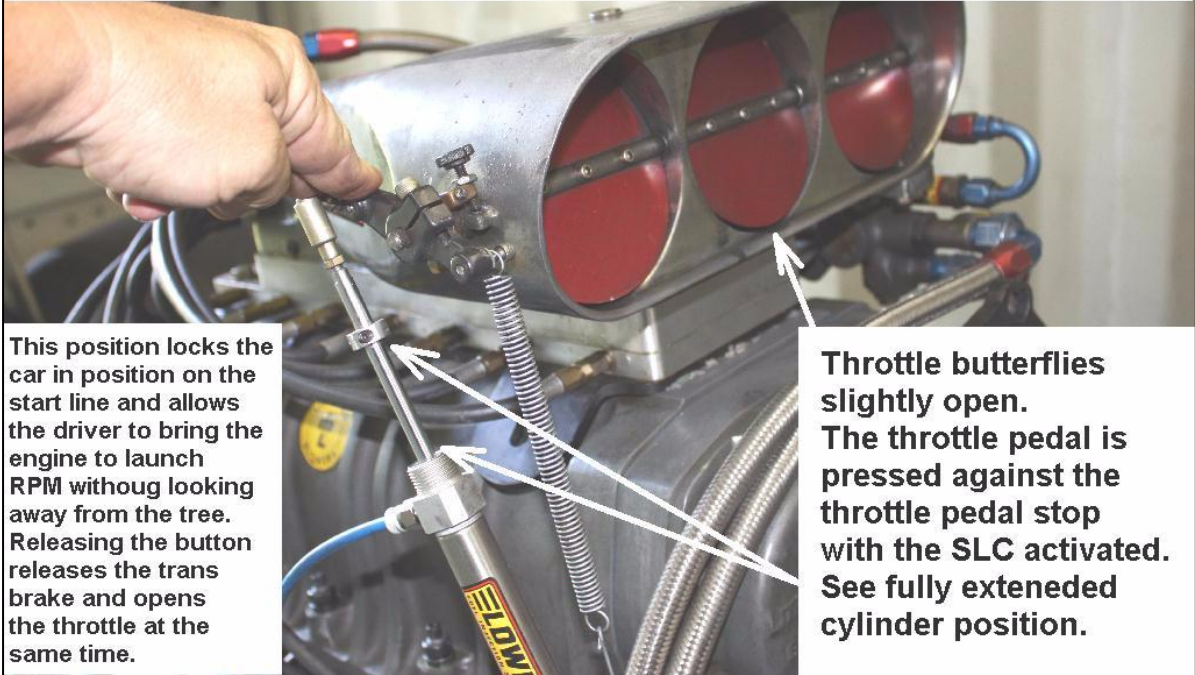

This position locks the car in position on the start line and allows the driver to bring the engine to launch RPM without looking away from the tree. Releasing the button releases the trans brake and opens the throttle at the same time.

Throttle butterflies slightly open. The throttle pedal is pressed against the throttle pedal stop with the SLC activated. See fully extended cylinder position.

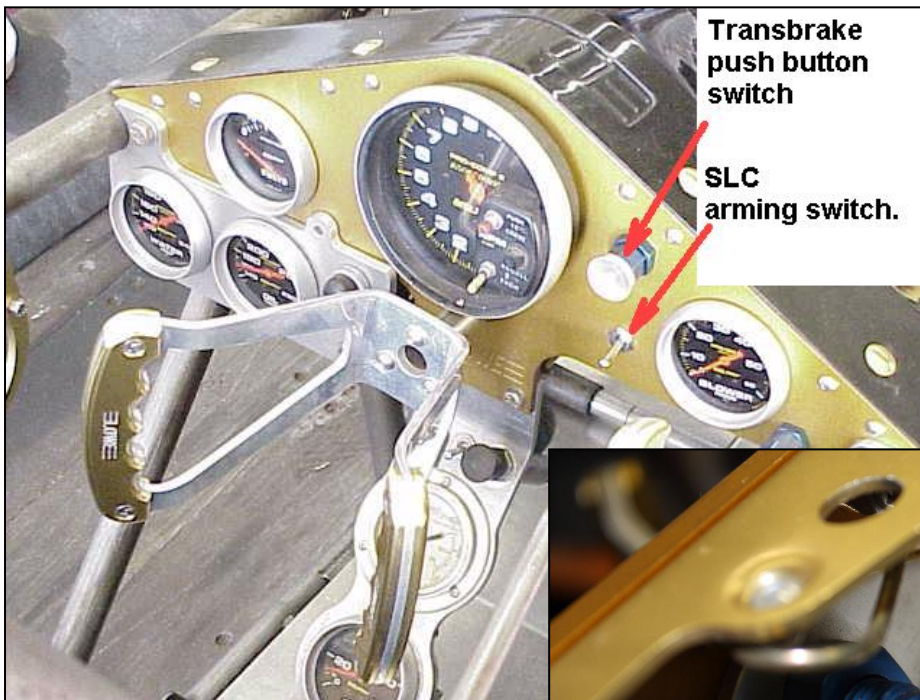

Transbrake push button switch

SLC arming switch.

The SLC arming switch supplies power to the SLC solenoid. This arming switch is a single pole single throw SPST switch available from any auto electrical supply. Use a robust switch with a 20amp minimum rating.

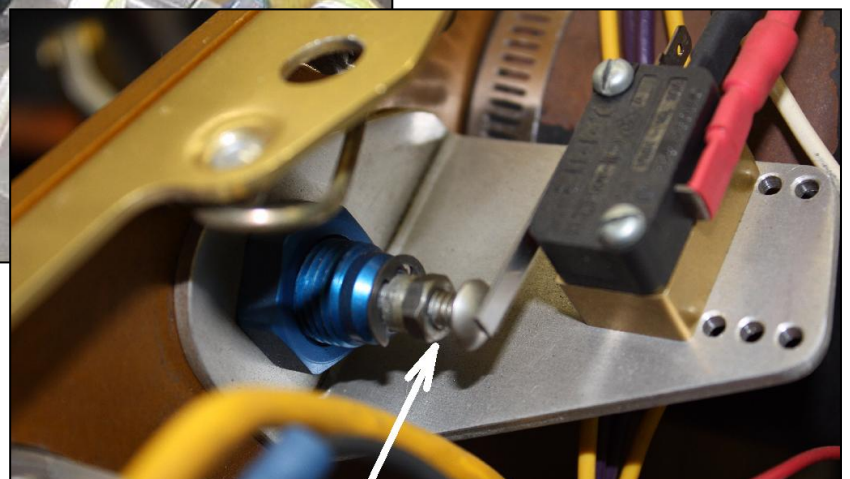

**Adjustable stroke transbrake switch**