

Supercharger crankshaft hub installation instructions

The *KEN LOWE RACE CARS* supercharger crankshaft hub is made to be compatible with all standard blower pulleys. We manufacture the hub with the offset bolt hole to make it easier to bolt any standard pulley on the hub.

The *KEN LOWE RACE CARS* supercharger crankshaft drive hub is made from high quality 4140 steel. We have designed this hub to be as strong as possible to solve the galling and keyway problems found in other hubs. The keyway has been cut to a proper depth in this hub. When you cut the keyway in the crankshaft to match, it should be cut so there is no more than .005 clearance between the top of the key and the inside of the hub keyway slot. By reducing this clearance it will help keep the key from "rocking" in the keyway. This rocking will lead to galling of the metal on the crank nose and the drive hub causing early failure of the hub assembly. DO NOT use hardened keys in this application.

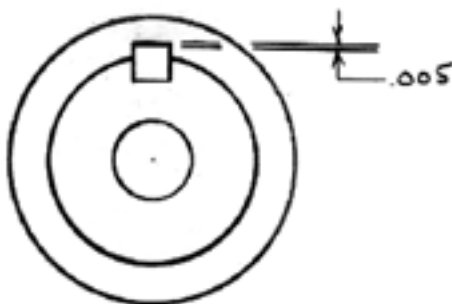

The *KEN LOWE RACE CARS* supercharger drive hub comes with only one 1/4" keyway. We can supply double keyways if so desired. We feel it is not necessary as the accurate indexing between the keyways is difficult and as such usually one of the keys takes the most load anyhow. The removal of extra metal

on the hub and the crankshaft makes both of these weaker as well. For these reasons almost all Top Alcohol Dragster and Funny Cars do not use dual keyways now.

Small block Chevy

Chevy small block crankshafts are ground to size from 1.2480" to 1.246" we want the hub to be snug on the crankshaft nose so we fit the hub to 1.2455" if the hub fits excessively tight on your crankshaft nose polishing the nose may be required. You want a minimum of .0005 (half a thou) tight fit. Warming the hub will assist with installation in some instances. It is important that the hub does not slide on the crankshaft easily because if it does it will move while the engine is running causing galling of the hub and crankshaft. We have honed the inner bore of the hub before broaching the keyway in the hub. This insures a very accurate bore diameter and quality control.

The timing of the ignition can be aided with the use of the **KEN LOWE RACE CARS** timing ring. This ring comes without a TDC timing mark as most supercharged engines have some sort of fabricated timing pointer which doesn't align with the factory position. After you install the timing ring find the top dead centre of number one cylinder as if you were going to degree the camshaft. Now mark the timing ring to indicate your top dead centre of number one cylinder. Additional marks can be made at 90, 180, and 270 degrees to aid in setting the valve lash by indicating ever 90 degrees of crankshaft rotation. Also marking the timing ring around the area where the timing will be set should be done as well. This is usually 30-45 degrees before top dead centre.

Installing the timing ring

Put the hub on a pair of steel blocks with the pulley mounting face down. Hold the timing ring with a pair of long pliers or grips and heat the ring with a torch to a temperature where a moistened finger will sizzle (much like your mother would check the iron before ironing). Once the ring is hot enough lay the ring over the outside diameter of the crank hub. Allow to cool before moving.



Small Block Chevy

36535-01100 Crank hub without timing ring ..
36535-11100 Crank hub with timing ring installed.
36600-63750 Timing ring 6.375 DIA (not installed)

Big Block Chevy

36535-01200 Crank hub without timing ring.
36600-63750 Timing ring 6.375 DIA (not installed)
36535-11200 Crank hub with timing ring installed.

Chrysler 426, 440, 392

36535-01300 Crank hub without timing ring
36535-11300 Crank hub with timing ring installed
36600-63750 Timing ring 6.375 DIA (not installed)

If you are using a KLRC crank hub it is counterweighted to give the engine balancer enough metal to balance with the rotating assembly. All counterweighted crank hubs must be balanced with the rotating assembly.

Please call us for your other supercharger components.